

1 HOUR FIRE RATED (ASTM E119) LOAD BEARING VERSAROC FLOOR ASSEMBLY

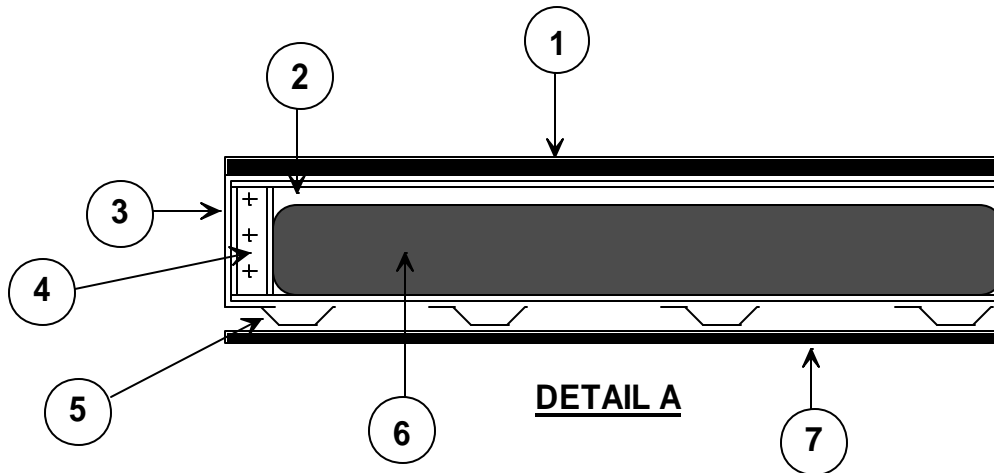

1. VERSAROC Board, 19mm (3/4" nominal) minimum thickness screw fastened direct to steel framing with #8 x 1-5/8" ITW Buildex S-12 Rock-On Climacoat screws.. Fastener spacing 12" o.c. along steel 'C' joists and at perimeter.
2. Galvanized steel 'C' joists, 8" minimum depth x 18 gauge minimum thickness x 1-5/8" minimum flange width. Joists spaced at 24" o.c. maximum. Double joists only at end of panel.
3. Galvanized steel 'perimeter channel' receiving ends of 'C' joists, 18 gauge minimum. Screw fastened to top & bottom flange of 'C' joist with #10 x 1/2" corrosion resistant self-drilling 'Tek' screws.
4. Galvanized steel web stiffener, 3-5/8" x 18 gauge, placed inside 'C' joist flange and screw attached to web of 'C' joist with three #10 x 1/2" corrosion resistant self-drilling 'Tek' screws.
5. Galvanized single leg resilient furring channel, 1/2" deep x 25 gauge minimum at 16" o.c. screw fastened to bottom flange of 'C' joist with #10 x 1/2" corrosion resistant self-drilling 'Tek' screws.
6. Mineral wool insulation 4 lbs. pcf density x 4" thick x 24" wide batts in joist cavity..
7. Single layer of 5/8" Type 'X' gypsum board, screw fastened to resilient furring channels with #6 x 1" drywall screws at 12" o.c.

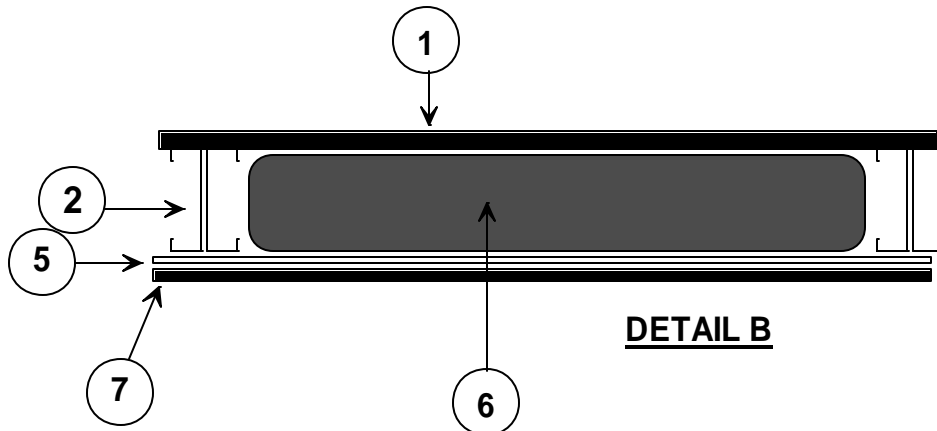

DETAILS NOT TO SCALE